

ASTRO 4 Semi

Create Sustainable and Efficient Green Energy



ASTRONERGY
A CHINT COMPANY

370W~380W

Monocrystalline PV Module
CHSM60M-HC Series (166)



KEY FEATURES

+5W

OUTPUT POSITIVE TOLERANCE
Guaranteed 0~+5W positive tolerance to ensure power output.



INNOVATIONAL HALF-CUT TECHNOLOGY
Better shading tolerance, higher reliability.



INNOVATIONAL MULTI-BUSBAR TECHNOLOGY
Higher light absorption, lower risk of microcrack.



SUPER PERC+ CELL TECHNOLOGY
Higher module power and module efficiency, lower power degradation.

Anti PID

PID RESISTANCE
Excellent PID resistance.

WARRANTY

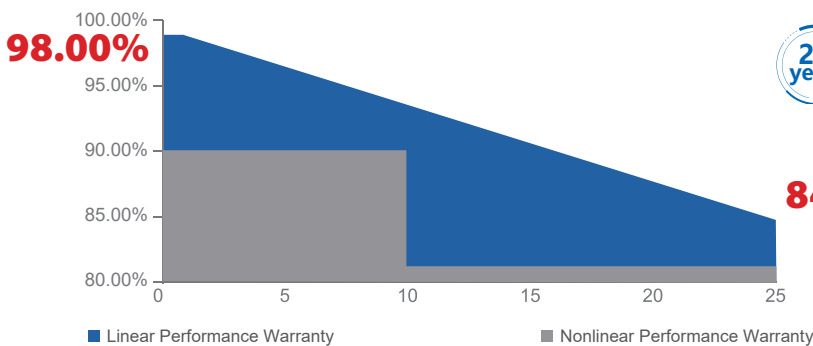

15 years Warranty for Materials and Processing
(special for rooftop market)



25 years Warranty for Extra Linear Power Output
(1st year ≤ 2.0%, 2nd~25th years ≤ 0.55% / year)

84.80%

Designed for the Australian Market



ELECTRICAL SPECIFICATIONS

STC rated output (P_{mpp})	370 Wp	375 Wp	380 Wp
Rated voltage (V_{mpp}) at STC	33.98 V	34.28 V	34.51 V
Rated current (I_{mpp}) at STC	10.89 A	10.94 A	11.01 A
Open circuit voltage (V_{oc}) at STC	40.75 V	41.05 V	41.34 V
Short circuit current (I_{sc}) at STC	11.35 A	11.42 A	11.49 A
Module efficiency	20.3%	20.6%	20.9%
Rated output (P_{mpp}) at NMOT	275.9 Wp	279.6 Wp	283.4 Wp
Rated voltage (V_{mpp}) at NMOT	31.68 V	31.96 V	32.18 V
Rated current (I_{mpp}) at NMOT	8.71 A	8.75 A	8.81 A
Open circuit voltage (V_{oc}) at NMOT	38.31 V	38.59 V	38.87 V
Short circuit current (I_{sc}) at NMOT	9.13 A	9.19 A	9.24 A
Temperature coefficient (P_{mpp})	- 0.35%/°C		
Temperature coefficient (I_{sc})	+ 0.050%/°C		
Temperature coefficient (V_{oc})	- 0.27%/°C		
Nominal module operating temperature (NMOT)	41±2° C		
Maximum system voltage (IEC/UL)	1500V _{DC}		
Number of diodes	3		
Junction box IP rating	IP 68		
Maximum series fuse rating	20 A		

Power Sorting: 0~+5W

* Measurement tolerance +/- 3%

STC: Irradiance 1000W/m², Cell Temperature 25°C, AM=1.5

NMOT: Irradiance 800W/m², Ambient Temperature 20°C, AM=1.5, Wind Speed 1m/s

MECHANICAL SPECIFICATIONS

Outer dimensions (L x W x H)	1755 x 1038 x 30 mm
Frame technology	Aluminum, black anodized
Front glass thickness	3.2 mm
Cable length (IEC/UL)	1200 mm
Cable diameter (IEC/UL)	4 mm ² / 12 AWG
① Maximum mechanical test load	5400 Pa (front) / 2400 Pa (back)
Fire performance (IEC/UL)	Class C (IEC) or Type 4 (UL)
Connector type (IEC/UL)	MC4-EVO2

① Refer to Astronergy crystalline installation manual or contact technical department.
Maximum Mechanical Test Load=1.5×Maximum Mechanical Design Load.

PACKING SPECIFICATIONS

① Module Weight	19.5 kg
② Packing unit	36 pcs / box
Weight of packing unit (for 40'HQ container)	743 kg
Number of modules per 40'HQ container	936 pcs

① Tolerance +/- 1.0kg

② Subject to sales contract

MODULE DIMENSION DETAILS

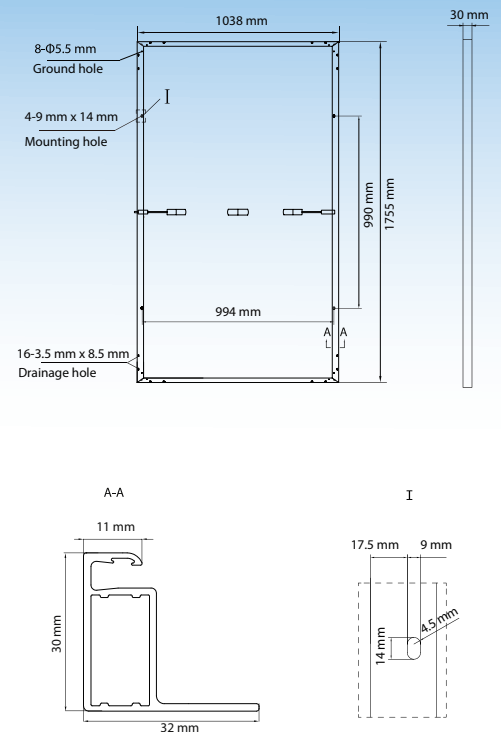

CURVE

